

# Laboratory Set Hot & Cold Mixing Unit Type 19

## PRODUCT CODES:

- TL19SJ1C

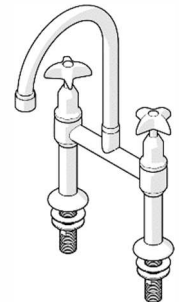

## SPECIFICATIONS

- Chrome plate finish for easy cleaning and durability.
- Replaceable top assemblies are supplied for easy maintenance.
- Simple servicing and readily available parts.
- Tough vandal resistant handle that has a unique locking system.
- Quality controlled. Every tap is tested.

**IMPORTANT:** All laboratory taps are tested in accordance with AS/NZS 3718 and leave our premises in good working order.

## TECHNICAL DATA

Inlet			½" BSP - Male
Outlet			Aerator
Headwork			Jumper Valve
Working Pressure Range (kPa)	Min	50	
	Max	500	
Working Temperature Range (°C)	Min	5	
	Max	80	
Nominal Flow Rate (LPM)			6.3
Construction			Brass
Finish			Chrome

**NOTE:** Galvin Engineering continually strive to improve their products. Specifications may change without notice.

## PRE-INSTALLATION

- Before installation, all lines must be flushed.
- Galvin Engineering recommends the installation of strainers and pressure reducing valves (when necessary) to ensure clean consistent supply. Debris or poor water quality could affect the performance of the unit.

## TOOLS REQUIRED

- Power drill
- Spanner or adjustable crescent
- Thread / sealant tape is used.

PRE-INSTALLATION - MOUNTING DETAILS

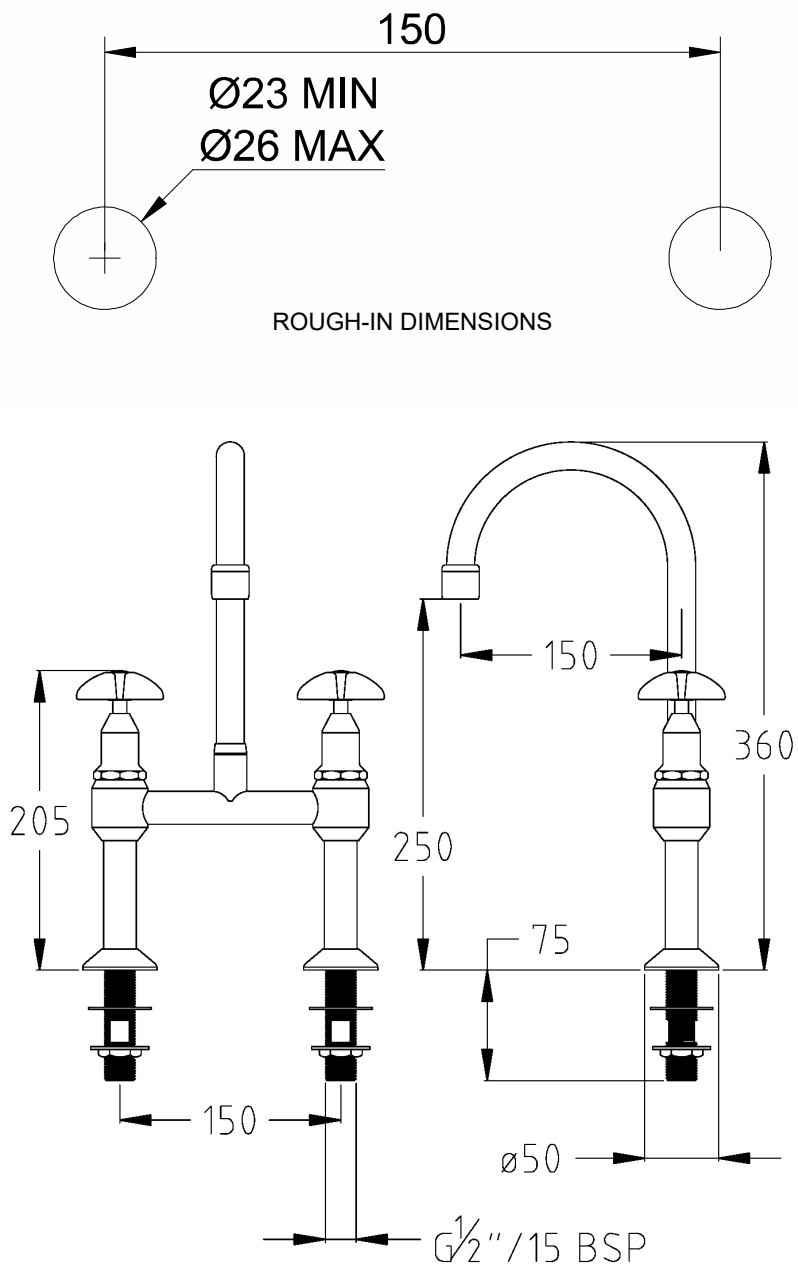

**INSTALLATION**

**IMPORTANT:** Galvin Engineering products must be installed in accordance with these installation instructions and in accordance with AS/NZS 3500, the PCA and your local regulatory requirements. Water and/or electrical supply conditions must also comply to the applicable national and/or state standards. Failing to comply with these provisions shall void the product warranty and may affect the performance of the product.

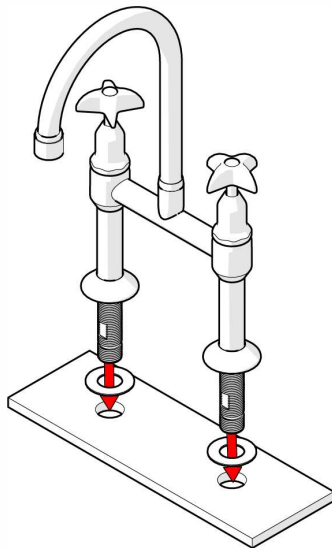

**1. Fit lab set body**

- Fit the lab set into the bench.

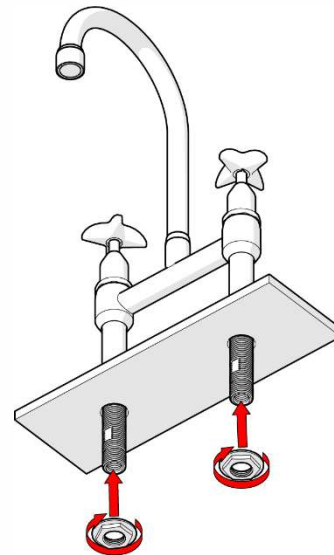

**2. Secure the outlet**

- Secure the body underneath with the supplied back nut.

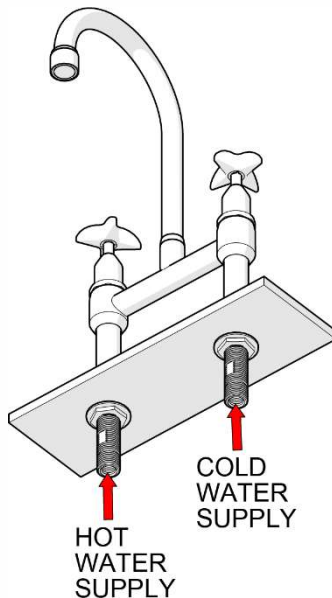

**5. Connect the water line**

- Connect water supply ensuring thread / sealant tape is used.

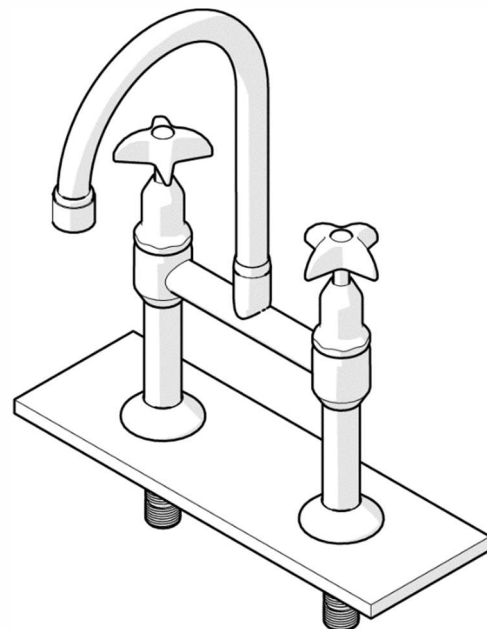

**6. Testing**

- Inspect the tap and check for any leaks.

TROUBLESHOOTING		
PROBLEM	CAUSE	RECTIFICATION
Water is not flowing or inconsistent flow.	Blocked aerator	Remove aerator from outlet and remove debris. Install an inline strainer to stop further blockages.
	Blocked flow restrictor.	Remove flow restrictor from the inlet and remove debris. Install an inline strainer to stop further blockages.

**WARRANTY**

The warranty set forth herein is given expressly and is the only warranty given by the Galvin Engineering Pty Ltd. With respect to the product, Galvin Engineering Pty Ltd makes no other warranties, express or implied. Galvin Engineering Pty. Ltd. hereby specifically disclaims all other warranties, express or implied, including but not limited to the implied warranties of merchantability and fitness for a particular purpose.

Galvin Engineering Pty Ltd products are covered under our manufacturer’s warranty available for download from [www.galvinengineering.com.au](http://www.galvinengineering.com.au) Galvin Engineering Pty Ltd expressly warrants that the product is free from operational defects in workmanship and materials for the warranty period as shown on the schedule in the manufacturer’s warranty. During the warranty period, Galvin Engineering will replace or repair any defective products manufactured by Galvin Engineering without charge, so long as the terms of the Manufacturer’s warranty are complied with.

The remedy described in the first paragraph of this warranty shall constitute the sole and exclusive remedy for breach of warranty, and Galvin Engineering Pty Ltd shall not be responsible for any incidental, special or consequential damages, including without limitation, lost profits or the cost of repairing or replacing other property which is damaged if this product does not work properly, other costs resulting from labour charges, delays, vandalism, negligence, fouling caused by foreign material, damage from adverse water conditions, chemical, electrical or any other circumstances over which Galvin Engineering has no control. This warranty shall be invalidated by any abuse, misuse, misapplication, improper installation or improper maintenance or alteration of the product.